

SATO Europe GmbH

M5900RV Printer Operation Manual



SATO EUROPE
Halskestr. 15-19
40880 Ratingen
Germany

Tel.: +49 (0)2102 5566-0
Fax.: +49 (0)2102 5566-555

This page is intentionally left blank.

Warning

It is essential that the safety and operating procedures contained within this manual be brought to the attention of, and are used by, all personnel likely to operate this printer/product.

This printer/product must only be used for the purpose for which it was designed.

This is a Class A product. In a domestic environment this product may cause radio interference in which case the user may be required to take adequate measures.

Electrostatic discharges on the connector pins and on the memory card may damage the printer.

In the case of fire, water must not be used on the product to extinguish the fire, and the appropriate type of fire extinguisher should be readily available.

No modifications, either mechanical or electrical, should be made to this printer/product or accessory without the written consent of SATO Europe GmbH. Any modifications made without this consent may invalidate guarantee claims.

Other manuals relating to this printer include additional information relating to other aspects of the safe operation of the printer, and are available from your SATO supplier.

All consumable waste, such as the label backing paper must be disposed of carefully, and in a manner that will cause the minimum of environmental pollution.

Should you have any doubts regarding the setting, operating or any safety aspects of this printer/product, please contact your SATO supplier.

SATO Europe GmbH makes no guarantee that all the features described in this manual are available in all models, and, due to SATO's policy of continuous development and improvement, specifications are liable to change, without notice.

Consumables

The use of incorrect materials may cause malfunctions of the printer and void the warranty.

Conventions

Text that appears bold italic and all in capitals such as **LABEL** refers to a key or an LED on the operation panel.

Text that appears enclosed in brackets such as <ESC> refers to an Escape sequence of a data string.

Text that appears bold italic such as **On-Line** refers to a function or to a result.

Text that appears in bold such as **VR1** refers to electrical components like pins, resistors connectors and so on.

Warranty and Copyright

SATO Europe GmbH makes no guarantee of any kind with regard to this material, including, but not limited to, the implied guaranties of merchantability and fitness for a particular purpose.

SATO Europe GmbH shall not be liable for errors contained herein or for any incidental consequential damages in connection with the furnishing, performance, or use of this material.

This document contains proprietary information which is protected by copyright.

All rights are reserved.

No part of this document may be reproduced or issued to third parties in any form whatsoever without the express permission of SATO Europe GmbH.

The information in this document is subject to change without notice.

© Copyright 1999 SATO Europe GmbH

Contents

1. Specifications	7
2. Introduction	11
2.1 Installation Considerations	11
2.2 Dimensions	12
2.3 Component Designations	13
2.4 Rear Panel	14
2.5 Switches And Sensors	15
2.6 Operation Panel	16
3. Printer Configuration	17
3.1 DIP Switch Settings	17
3.1.1 RS232 Transmit/Receive Setting	18
3.1.2 Selecting Protocol Control Codes	21
3.2 Default Settings	26
3.3 Printer Adjustments	27
3.3.1 Normal Mode	27
3.3.2 User Mode	27
3.3.3 Print Darkness Setting	28
3.3.4 Print Speed Adjustment	28
3.3.5 Pitch Offset and Direction	29
3.3.6 Cancel print Job	30
4. Interface Specifications	31
4.1 Overview	31
4.2 Interface Types	31
4.3 The Receive Buffer	32
4.4 RS232C Serial Interface	33
4.5 Centronics Parallel Interface	40
4.6 Accessory (EXT) Connector	41
5. Loading Labels	43
6. Troubleshooting	47
6.1 Overview	47
6.2 Initial Checklist	48
6.3 Troubleshooting the Centronics (Parallel) Interface	48
6.4 Troubleshooting the RS232C (Serial) Interface	50
6.5 Error Signals	51

6.6	Print Quality Problems	52
7.	Cleaning and Maintenance	55
7.1	Cleaning the Print Head and Platen	56
7.1.1	Cleaning the Print Head (Print Head Cleaner)	56
7.1.2	Cleaning the Print Head (Lapping Film)	57
7.2	Cleaning the Platen and Label Guides	58
7.3	Cleaning the Sensors	59
Appendix	61

1. Specifications

Print Method	Direct Thermal
Print Mode	Batch, Tear-Off, Cutter, Dispenser
Font Type	U (5x9 Helvetica) U (17x17 Times New Roman) with DSW2-8=on S (8x15 Helvetica) M (13x20 Helvetica) WB (18x20 Helvetica) WL (28x52 Helvetica) XU (5x9 Helvetica) XS (17x17 UCB) XM (24x24 UCB) XB (48x48 UCB) XL (48x48 Sancerif) OCR-A (15x22), OCR-B (20x24) Vector Font Kanji Font (16x16, 24x24 JIS type) as option
Bar codes	CODABAR, Code39, EAN-8/13, UPC-A/-E, Interleaved 2 of 5, Industrial 2 of 5, MSI, Bookland, UCC/EAN-128, Code93, Code128, 2D code (PDF417, Maxicode, Datamatrix)
Bar Ratio	1:2, 1:3, 2:5 User definable bar widths
Font Expansion	Up to 12x in either the X or Y
Interface	1 Interface Card Selectable Centronics or RS232C as standard RS422/485 as option Twinax/Coax EXT Port as standard (for outgoing signals)
Message Display	LCD (16-digits x 2 lines)
LEDs	NO
Dimensions	260 (w) x 322 (d) x 280 (h) mm
Weight	Approx. 9.8 Kg
Operation Switch	Line key, Feed key
Setting Switch	2 on Operation panel, 1 on RS232C card
Calendar	Dallas IC for Real Time Calendar as option

CPU	RISC 32bit x 1
Memory Capacity	Program ROM : 512K byte x 1, Masked Font ROM : 512K byte x 1 D-RAM : 2M Byte x 1, EEPROM : 8K byte x1
Pitch Sensor	See-thru, and Reflective Eye-mark
Self-diagnostics function	Head Check, Paper end, Head open, Self Test print, Memory card error
Options	Cutter, Dispenser, Rewinder, Card PCB, Kanji IC, Kanji Outline font card, Dallas IC
Print Resolution	8 dots / mm (.125 mm) TDK P/H
Maximum Print Area	Standard : 112 mm (W) x 178 mm (L) Expanded : 112 mm (W) x 356 mm (L)
Print Speed	2,3,4,5 ips User selectable (Default : 3 ips)
Print Darkness	5 steps selectable
Rotation	0, 90, 180, 270 degree
Voltage	AC 115/230 \pm 10% (Switchable) 50/60 Hz \pm 1%
Power Consumption	Maximum 190VA 130 W
Environmental	Operating Temperature +5 ~ +40_C, Humidity 30 ~ 80 % RH, non-condensing Storage Temperature -5 ~ +60_C, Humidity 30 ~ 90 % RH, non-condensing
RFI/EMI	FCCI Class-B, AC Line Noise 1000Vp or more (50nS ~ 1microS pulse)
Potentiometer	For adjustment x 3 (Print offset, Print darkness, Cut/Dispensing position)
Safety	CE, UL, CSA, TÜV

Sato Standard Label		
Batch	Size	Width : 37 ~ 128 mm (40 ~ 131 mm including backing paper) Length : 25 ~ 356 mm (28 ~ 359 mm including backing paper)
	Caliper	0.08 ~ .021 mm
Dispenser	Size	Width : 37 ~ 128 mm (40 ~ 131 mm including backing paper) Length : 25 ~ 356 mm (28 ~ 359 mm including backing paper)
	Caliper	0.1 ~ 0.16 mm
Cutter	Size	Width : 37 ~ 162 mm (40 ~ 165 mm including backing paper) Length : 25 ~ 356 mm (28 ~ 359 mm including backing paper)
	Caliper	0.08 ~ 0.21 mm
Tear-off	Size	This will depend on the media condition as material, size, print quantity, etc.,
	Caliper	0.08 ~ 0.16 mm
Media Type		Roll Type : Face in O.D 6 inch (approx. 75m) I.D 4 inch Fan fold type up to 100mm via rear cover

This page is intentionally left blank.

2. Introduction

The SATO M5900RV Printer Operation Manual provides information for installing and maintaining the SATO M5900RV printer. Step-by-step maintenance instructions are included in this manual with typical problems and solutions. It is recommended that you become familiar with each section in this manual before installing and maintaining the printer. This manual is divided into the following six sections:

- Chapter 1 - Specification
- Chapter 2 - Introduction
- Chapter 3 - Printer Configuration
- Chapter 4 - Interface Specifications
- Chapter 5 - Loading Labels
- Chapter 6 - Troubleshooting
- Chapter 7 - Cleaning and Maintenance
- Appendix

2.1 Installation Considerations

Printer operation can be affected by the printer environment. The location of the printer should be free from dust, humidity, and sudden vibrations. To obtain optimum results from the printer, avoid locations influenced by:

- Direct or bright sunlight since bright light will make the label sensor less responsive and may cause the label to be sensed incorrectly.
- Warm temperatures which can cause electrical problems within the printer.

2.2 Dimensions

NOTE: The exact position of components may vary, depending on the model.

Width 260 mm

Depth 322 mm

Height 280 mm

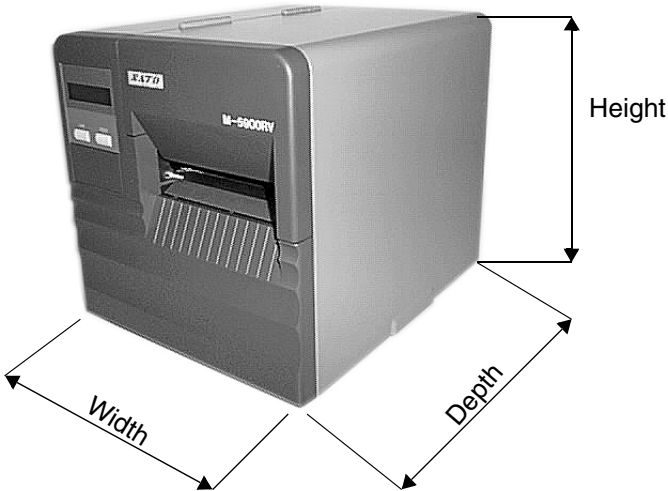

2.3 Component Designations

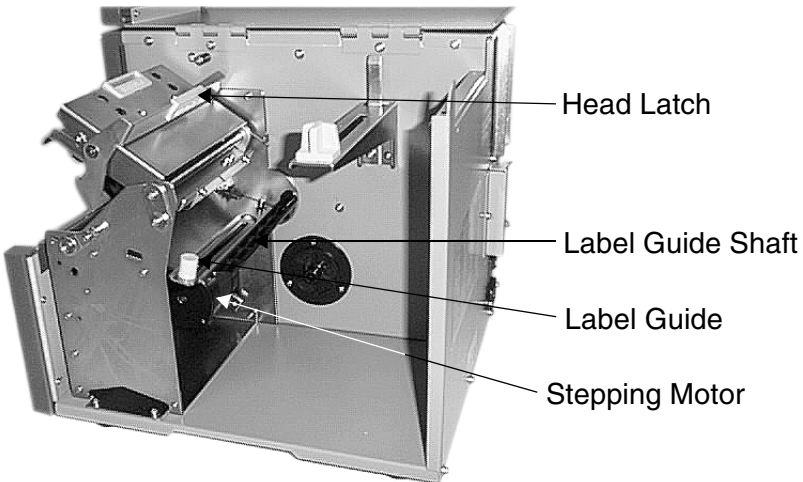
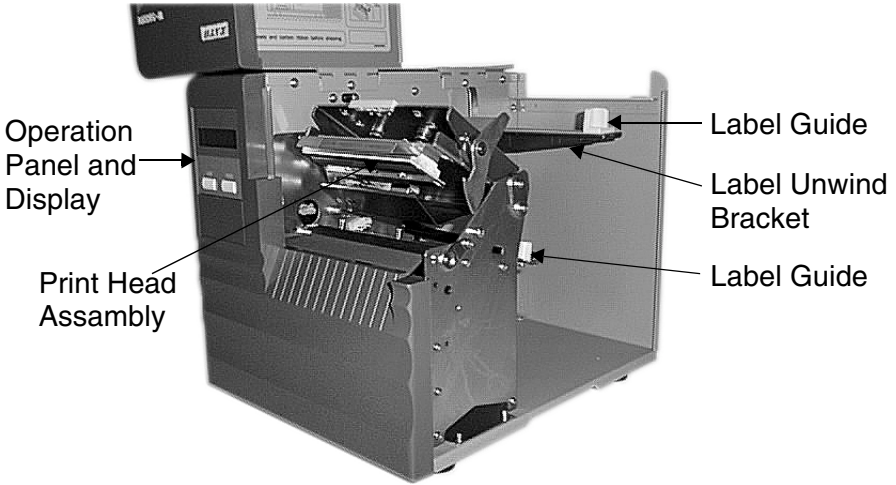

2.4 Rear Panel

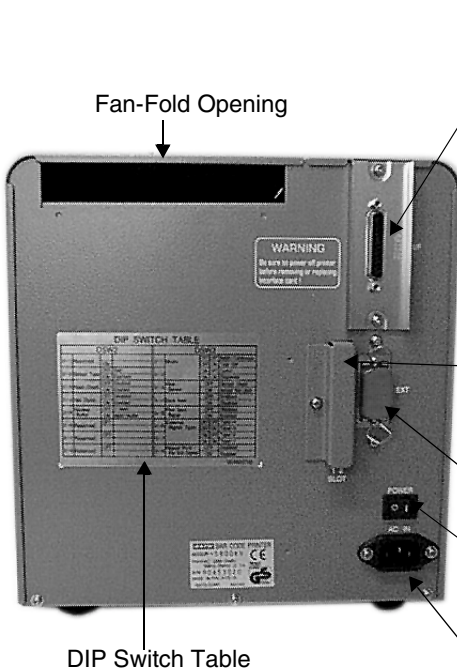

Boards are supplied with the following connectors:
CENTRONICS CONNECTOR:
 For printer using parallel communication connection or
RS232 CONNECTOR:
 For printer using serial communication connection or
TWINAX/COAX CONNECTOR:
 For printer operating in a mini/mainframe computer environment.

MEMORY CARD SLOT 1 & 2:
 Optional connectors for use with PCMCIA Memory Cards.

EXT. CONNECTOR:
 This is an external signal connector.

POWER ON/OFF SWITCH:
 To turn power On or Off

AC INPUT CONNECTOR:
 To input 220V 50/60 Hz. Use power cable provided.

2.5 Switches And Sensors



Head Open Switch.
When the print head is opened, this switch is activated and the printer will stop printing.

I-Mark Sensor
(reflective)

Gap Sensor
(transmissive)



2.6 Operation Panel

LINE Key: Momentary switch. Pressing this key toggles the printer between the on-line and off-line mode. When the printer is on-line, it is ready to receive data from the host. This key acts as a pause during a print job by taking the printer off-line. It can also be used as a pause function key to stop the printer during the printing process.

FEED Key: Momentary switch. Pressing this key feeds one blank label through the printer when it is off-line. When the printer is on-line, another copy of the last label will be printed.

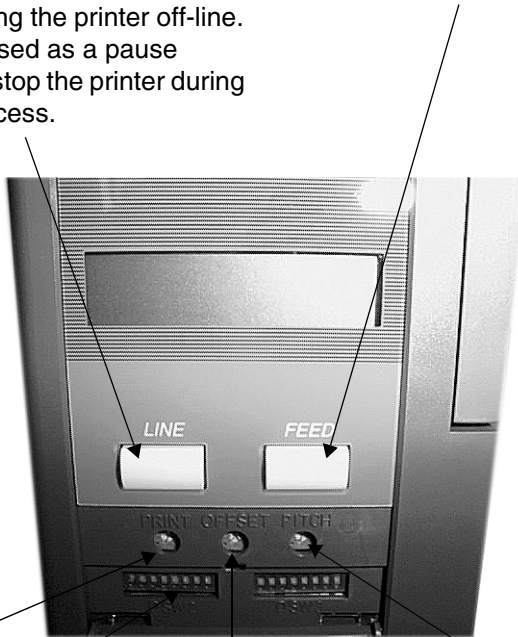

PRINT Potentiometer:
To adjust print darkness
(fine adjustment).

OFFSET Potentiometer:
To adjust back/forward
feed for dispenser
(+/- 3.75mm).

PITCH Potentiometer:
Adjusts home position of
the label(+/- 3.75mm).
Affects stop position of
label feed, print position,
and dispense position.
Larger adjustments
should be made using the
Pitch Offset function.

DSW2 & 3: DIP Switches to set operational parameters of printer.
NOTE: Optional RS232 Communication Card contains DSW1 switches which are configured when supplied with the printer.

3. Printer Configuration

3.1 DIP Switch Settings

Two DIP switches DSW2 and DSW3 are located under the front door panel and a DSW1 switch is located on an optional RS232 serial interface board.

These switches can be used to set:

- RS232C transmit/receive parameters
- Label sensor enable/disable
- Head check mode
- Hex dump mode
- Receive buffer size
- Operation mode

**DIP Switch Panel Layout for DSW1
Located on RS232 Interface Board**

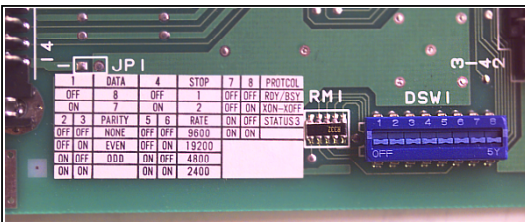

To set the switches, first power the unit Off, then position the DIP switches. After placing the switches in the desired positions, power the printer back on. The switch settings are read by the printer electronics during the power up sequence. They will not become effective until the power is cycled.

3.1.1 RS232 Transmit/Receive Setting

Data Bit Selection (DSW1-1)

This switch sets the printer to receive either 7 or 8 bit data bits for each byte transmitted.

DSW1-1	SETTING
*OFF	8 Data Bits
ON	7 Data Bits

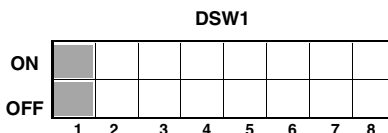

Parity Selection (DS1-2, DS1-3)

These switches select the type of parity used for error detection.

DSW1-2	DSW1-3	SETTING
*OFF	*OFF	No Parity
OFF	ON	Even
ON	OFF	Odd
ON	ON	Not Used



Stop Bit Selection (DS1-4)

Selects the number of stop bits to end each byte.

DSW1-4	SETTING
*OFF	1 Stop Bit
ON	2 Stop Bits



Baud Rate Selection (DS1-5, DS1-6)

Selects the data rate(bps) for the RS232 port.

DSW1-5	DSW1-6	SETTING
*OFF	*OFF	9600
OFF	ON	19200
ON	OFF	4800
ON	ON	2400

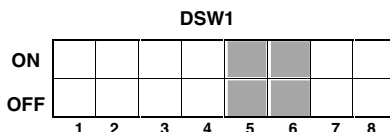

* Factory Default

Communication Protocol Selection (DS1-7, DS1-8)

Selects the flow control and status reporting.

DSW1-7	DSW1-8	SETTING
*OFF	*OFF	Rdy/Bsy
OFF	ON	Xon/XOff
ON	OFF	Bi-Com
ON	ON	Not Used

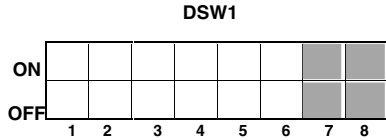

***DS2-1 reserved**

Sensor Type Selection (DS2-2)

Selects type of sensing.

DSW2-2	SETTING
*OFF	Gap
ON	"I" Mark

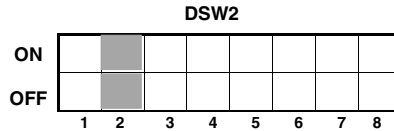

Head Check Selection (DS2-3)

When selected, the printer will check for head elements that are electrically malfunctioned.

DSW2-4	SETTING
*OFF	Disabled
ON	Enabled

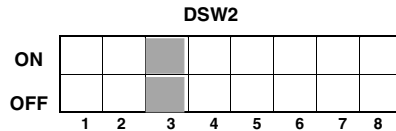

*** Factory Default**

Hex Dump Selection (DS2-4)

Selects Hex Dump mode.

DSW2-3	SETTING
*OFF	Disabled
ON	Enabled



Receive Buffer Selection (DS2-5)

Selects the operating mode of the receive buffer.

Note: The Centronics interface operates only in the multi job buffer mode regardless of the switch setting.

DSW2-5	SETTING
OFF	Single Job
ON	Multi Job

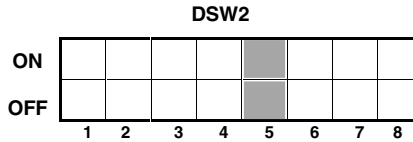

Protocol Control Code Selection (DS2-6 & DS2-7)

Selects the command codes used for protocol control.

DSW2-6-	DSW2-7	SETTING
Reserved	*OFF	Standard
Reserved	ON	Non - Std.

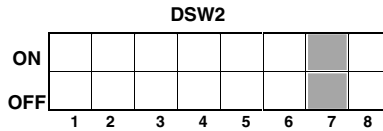

* Factory Default

3.1.2 Selecting Protocol Control Codes

Protocol control codes are the special control characters that prepare the printer to receive instructions. For example, the <ESC> character tells the printer that a command code will follow and the <ENQ> character asks for the printer status.

There are two pre-defined sets of Protocol Control codes to choose from. Each set is made up of six special characters. The Standard Protocol Control codes are non-printable characters, and the Non-Standard Protocol Control codes are printable characters. The Non-Standard set may be useful on host computers using protocol converters or in an application where non-printable ASCII characters cannot be sent from the host. This manual uses the Standard Protocol Control codes for all of the examples. Alternately, the user may define and download a set of custom Protocol Control Codes.

CONTROL CHARACTER	STANDARD DSW2-7 OFF	NON-STANDARD DSW2-7 ON	DESCRIPTION
STX	02 Hex	7B Hex = {	Start of Data
ETX	03 Hex	7D Hex = }	End of Data
ESC	1B Hex	5E Hex = ^	Command code to follow
Null	00 Hex	7E Hex = ~	Cutter command
ENQ	05 Hex	40 Hex = @	Get printer status, Bi-Com mode
Can	18 Hex	21 Hex = !	Cancel print job, Bi Com mode
Off-Line	40 Hex	5D Hex =]	Take printer Off-Line

Emulation Mode (DS2-8)

This command will allow you to use the M5900 command as backward compatibility.

DSW2-8	SETTING
*OFF	Disable
ON	Enable

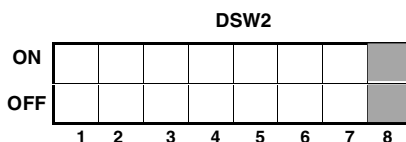

- Both CR and LF codes, which are included in the data except for a graphic or bar codes, will be discarded.
- Print Speed

Speed Steps	DSW2-8=Off	DSW2-8=On
50 mm/s	<CS>2	<CS>1 or <CS>2
75 mm/s	<CS>3	<CS>3
100 mm/s	<CS>4	<CS>4
125 mm/s	<CS>5	<CS>5
Others	Invalid	Invalid

3. Proportional Font

Proportional Font		DSW2-8=Off	DSW2-8=On
Helvetica	5W x 9L	<XU>	
Times Roman	17W x 17L		<U>
Universal Condensed Bold	17W x 17L	<XS>	<S>
	24W x 24L	<XM>	<M>
	48W x 48L	<XB>	<WB>
	48W x 48L	<XL>	<WL>

*Under the emulation mode, old fonts for the M84xx are deactivated on the printer.

Note: The format storage function with an internal memory of the printer is not supported with this mode.

Mode Selection (DS3-1 and DS3-2)

Selects the operating mode of the printer. Batch/Continuous disables the label sensors.

DSW3-1	DSW3-2	SETTING
OFF	OFF	Batch/Continuous
OFF	ON	Tear Off
ON	OFF	Cutter
ON	ON	Dispenser

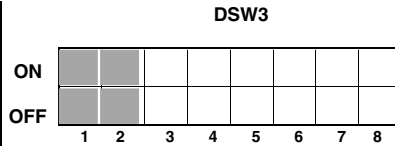

Label Sensor Selection (DS3-3)

Enables or disables the Label Sensor. If the Sensor is enabled, it will detect the edge of the label and position it automatically. If it is disabled, the positioning must be under software control using Line Feed commands.

DSW3-3	SETTING
*OFF	Sensor Used
ON	Enables Continuous Operation

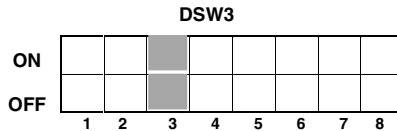

*** Factory Default**

Back Feed Selection (DS3-4)

When Back-Feed is enabled, the printer will position the label for dispensing/cutting and retract it to the correct print position before printing the next label.

DSW3-4	SETTING
*OFF	Enabled
ON	Disabled



Note: Back Feed function only works, if Tear Off, Cutter or Dispenser is selected. See DS3-1, 3-2.

External Signal Interface

The EXT connector on the CL printer rear panel is intended for use with the external printer accessories such as label rewinders or applicators. The 14-pin Centronics type connector provides a choice of four different output signals along with various error conditions.

Print Start Signal Selection (DS3-5)

DSW3-5	SETTING
*OFF	Disabled
ON	Enabled

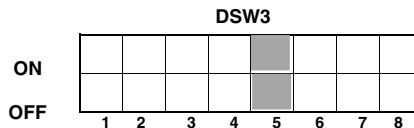

DSW3-6	DSW3-7	SETTING
*Off	Off	Type 4
Off	On	Type 3
On	Off	Type 2
On	On	Type 1

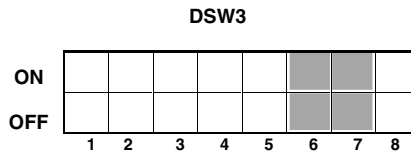

(Output on Pin 6)

*** Factory Default**

Repeat Print via External Signal (DSW3-8)

DSW3-8	SETTING
*OFF	Disabled
ON	Enabled

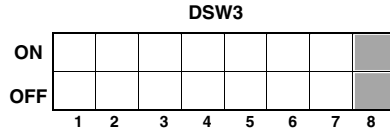

Note: The DIP Switch functions listed incorporate the latest firmware revisions at the time of printing.

* Factory Default.

3.2 Default Settings

Switch Selections

All switches are placed in the **OFF** position (default) for shipping. This will result in the following operating configuration:

- Communications: 8 data bits, no parity, 1 Stop bit, 9600 Baud
- Protocol: Ready/Busy
- Sensor: Gap Sensor
- Receive Buffer: Single Job
- Mode: Batch/continuous
- Pitch: Sensor Used
- Back feed: Disabled
- External Signals: Disabled

Software Default Settings

The M5900RV stores the software settings upon receipt and uses them until they are again changed by receipt of a command containing a new setting. These settings are stored in non-volatile RAM and are not affected by powering the printer off. The printer may be reset to use the default software settings by depressing the **LINE** and **FEED** keys simultaneously while powering the printer on. This will result in the following default configuration:

- Print Darkness: "3"
- Print Speed: 75 mm per second
- Print Reference: Vertical = 0001, Horizontal = 0001
- Zero: Slash
- Auto On Line: Enabled

Once the default operation is completed, a "DEFAULT SETTING COMPLETED" message will be displayed on the LCD panel. The printer should be powered off while this message is being displayed. This saves the default settings in the EEPROM where they will be automatically loaded the next time the printer is powered on.

<i>DEFAULT SETTING COMPLETED</i>

3.3 Printer Adjustments

The LCD Panel on the M5900RV printer is used in conjunction with the **LINE** and **FEED** switches by the operator to manually enter printer configuration settings. Many of the settings can also be controlled via software commands and in the case of conflict between software and control panel settings, the printer will always use the last valid setting. If you load a label job that includes software settings and then enter a new setting via the operation panel, the manually set values will be used by the printer. If you set the values manually and then download a job with software settings, the software settings will be used.

3.3.1 Normal Mode

When the printer is powered on, the readout should display the following message.

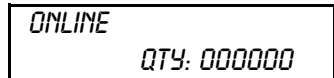

ONLINE
QTY: 000000

The LCD Panel will display the **ONLINE** status on the top line of the display and the bottom line will contain the label quantity (QTY) status. The **ONLINE** message will be changed to **OFFLINE** whenever the printer is switched **OFFLINE** by depressing the **LINE** key. As soon as a print job is received, the **QTY** message will indicate the number of labels to be printed. As soon as the label job begins to print, the display will indicate the number of labels remaining in the print job that remain to be printed.

3.3.2 User Mode

1. The printer is first taken offline by pressing the **LINE** key once. The display will change to:

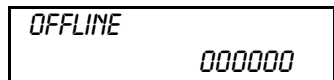

OFFLINE
000000

2. When the display changes to **OFFLINE**, press the **FEED** and **LINE** keys simultaneously for more than one second. The printer now displays the first **USER MODE** adjustment (Print Darkness).

3.3.3 Print Darkness Setting

There are five **PRINT DARKNESS** (or heat range) settings on the M5900RV, (1, 2, 3, 4, and 5). The higher numbers represent darker settings. The current setting is indicated by an underline under one of the range settings.

To change the setting perform the following steps:

1. Use the **LINE** key to step the underlined cursor to the desired setting.

<i>PRINT DARKNESS</i>				
1	2	<u>3</u>	4	5

2. Once the correct setting is underlined, press the **FEED** key to accept the setting and advance to the next adjustment.

Note: This setting can be overridden by software.

3.3.4 Print Speed Adjustment

There are four **PRINT SPEED** settings on the M5900RV, (2 = 50 mm/s, 3 = 75 mm/s, 4 = 100 mm/s, 5 = 125 mm/s). The setting is listed on the bottom line of the display. The current setting is indicated by an underline under one of the speed settings.

To change the setting perform the following steps:

1. Use the **LINE** key to step the underlined cursor to the desired setting.

<i>PRINT SPEED</i>			
2	<u>3</u>	4	5

2. Once the correct setting is underlined, press the **FEED** key to accept the setting and advance to the next adjustment.

Note: This setting can be overridden by software.

3.3.5 Pitch Offset and Direction

The label pitch is the distance from the leading edge (the edge that comes out of the printer first) of a label and the leading edge of the next label. The leading edge position of the label can be adjusted relative to the print head +/- 49 mm in increments of 1 mm using the following procedure. Once the position is set, it can be adjusted +/- 3.75 mm using the **PITCH** potentiometer on the adjustment panel.

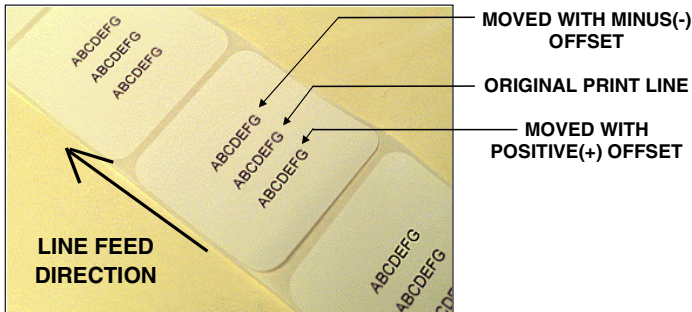

The label pitch is the distance from the leading edge (the edge that comes out of the printer first) of a label and the leading edge of the next.

To change the setting perform the following steps:

1. Use the **LINE** key to step the underlined cursor to either the positive (+) or the negative (-) selection. A positive selection increases the label pitch while a negative selection decreases the label pitch.
2. Once the correct setting is underlined, press the **FEED** key to accept the setting and advance to the **PITCH OFFSET** adjustment.

PITCH OFFSET
 ± 00 MM

3. Use the **LINE** key to step the counter to the desired position. The display will increment one step for each time the **LINE** key is pressed. If the **LINE** key is held mode. The reading will advance to a setting of 49 mm after which it will automatically wrap and start of "00" again. The pitch direction set in the previous step will be displayed in front of the **OFFSET** setting.

4. Once the setting is correct, press the **FEED** key to accept the setting and advance to the **CANCEL PRINT JOB** display.
5. You may wish to check your settings by printing a test label after you have completed the adjustments to ensure that they are correct.

3.3.6 Cancel print Job

If the printer has a print job(s) loaded in memory, selecting **YES** will cause the job(s) to be cleared. The default selection is **NO**. Make sure that you want to cancel the print job before selecting **YES** as the job cannot be recovered and will have to be retransmitted to the printer.

To cancel the print perform the following steps:

1. Use the **LINE** key to step the underlined cursor to either **YES** or **NO**.

CANCEL PRINT JOB	
<u>NO</u>	YES

2. Once the correct setting is underlined, press the **FEED** key to accept the setting and terminate the user mode of operation and return you to the normal mode **OFFLINE** display.

If you wish to change any of the settings, you must enter the user mode again by simultaneously pressing **FEED** and **LINE** keys for more than one second.

4. Interface Specifications

4.1 Overview

This section explains the interface specifications for the printer. These specifications include detailed information on how to properly interface your printer with your host system, and includes data about the following:

- Interface Types
- Using The Receive Buffer
- RS232C Serial Interface
- Centronics Parallel Interface
- Accessory (Ext) Connector

4.2 Interface Types

In order to provide flexibility in communicating with a variety of host computer systems, all printers can be configured for operation with either parallel or serial data transfers. Both a parallel Centronics or a serial RS232 interface are supplied with the standard printer.

The Centronics Parallel interface will probably be the most useful in communicating with IBM PCs and compatibles. The RS232C Serial interface allows connectivity to a number of other hosts. For instructions on how to properly configure the printer for either of these interface types, see the printer configuration instructions in Section 3 of this manual.

WARNING: Never connect or disconnect interface cables or use a switch box with power applied to either the host or the printer. This may cause damage to the interface circuitry in the printer/host and is not covered by warranty.

The receiving buffer will not be able to receive more data again until a "Buffer Available" condition occurs. This takes place when the receiving buffer has emptied so that only 56K bytes of data are being held (8K bytes from being full). At this time, **DTR** will go "high" or an **X-On** is sent to tell the host that it can again receive data.

All printer error conditions, will cause the printer to go busy (**DTR** "low" or **X-Off**) until the problem is corrected, and the printer is placed on-line. The printer will also be busy if taken off-line from the front panel.

4.3 The Receive Buffer

The printer has the ability to receive a data stream from the host in one of two ways. The receive buffer may be configured to accept one print job at a time or multiple print jobs. The single job print buffer is generally used by software programs that wish to maintain control of the job print queue so that it can move a high priority job in front of ones of lesser importance. The multiple job buffer, on the other hand, prints all jobs in the order they are received by the printer, and the order of printing cannot be changed.

Single Job Buffer

The printer receives and prints one job at a time. Each job must not exceed 64 K bytes.

Multi Job Buffer

The printer is able to continuously receive print jobs, compiling and printing other jobs at the same time. It acts much like a "print buffer" to maximize the performance of the host and the printer. When using the RS232 Serial interface, the Multi Job Buffer uses either the Ready/Busy with **DTR** (pin 20) or **X-On/X-Off** flow control protocols. See these sections for more details. With an empty receiving buffer, the status of **DTR** is "high" (or an **X-On** status if using **X-On/X-Off**), meaning the printer is ready to receive data. When the receive buffer is holding 62K bytes of data (2K bytes from being full), **DTR** will go "low" (or an **X-Off** is sent) indicating the printer can no longer receive data. This condition is called "Buffer Near Full". See Figure 3-1.

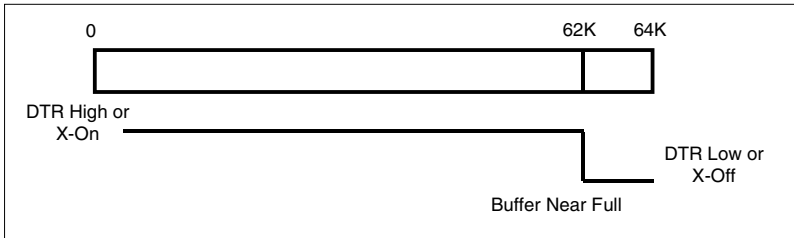

Fig. 3-1

The receiving buffer will not be able to receive more data again until a “Buffer Available” condition occurs. This takes place when the receiving buffer has emptied so that only 56K bytes of data are being held (8K bytes from being full). At this time, **DTR** will go “high” or an **X-On** is sent to tell the host that it can again receive data. See Figure 3-2.

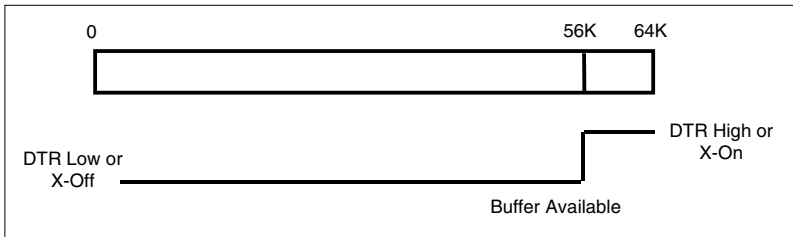

Fig. 3-2

4.4 RS232C Serial Interface

General Specifications

Asynchronous ASCII	Half-duplex communication. Ready/Busy Hardware Flow Control Pin 20, DTR Control Pin 4, RTS Error Condition X-On/X-Off Software Flow Control Bi-Directional communication (ENQ/Response)
Data Transmission Rate	2400, 4800, 9600 and 19200 bps
Character Format	1 Start Bit (fixed) 7 or 8 data bits (selectable) Odd, Even or No Parity (selectable) 1 or 2 Stop bits (selectable)

Electrical Specifications

Connector	DB-25S (Female)
Cable	DB-25P (Male), 5m or less length. For cable configuration, refer to Cable Requirements appropriate to the RS232C protocol chosen.
Signal Levels	High = +5V to +12V Low = -5V to -12V





Pin Assignments**RS232C Interface Signals**

PIN	DIRECTION	SIGNAL DESCRIPTION
1	Reference	FG (Frame Ground)
2	To Host	TD (Transmit Data) - Data from the printer to the host computer. Sends X-On/X-Off characters or status data (Bi-Directional protocol).
3	To Printer	RD (Receive Data) - Data to the printer from the host computer.
4	To Host	RTS (Request to Send) - Used with Ready/Busy flow control to indicate an error condition. RTS is high and remains high unless the print head is open, (in this case, RTS would return to the high state after the print head is closed and the printer is placed back on-line) or an error condition occurs during printing (e.g. label out).
5	To Printer	CTS (Clear to Send) - When this line is high, the printer assumes that data is ready to be transmitted. The printer will not receive data when this line is low. If this line is not being used, it should be tied high (to pin 4).
6	To Printer	DSR (Data Set Ready) - When this line is high, the printer will be ready to receive data. This line must be high before data is transmitted. If this line is not being used, it should be tied high (to pin 20).
7	Reference	SG (Signal Ground).
20	To Host	DTR (Data Terminal Ready) - This signal applies to Ready/Busy flow control. The printer is ready to receive data when this pin is high. It goes low when the printer is off-line, either manually or due to an error condition, and while printing in the Single Job Buffer mode. It will also go low when the data in the buffer reaches the Buffer Near Full level.

Ready/Busy Flow Control

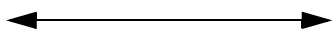
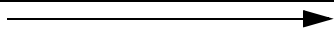
Ready/Busy is the hardware flow control for the serial interface on the printer. By raising/lowering the voltage level on Pin 20 of the RS232 port, the printer notifies the host when it is ready to receive data. Pin 4 (**RTS**) and Pin 20 (**DTR**) are the important signals on the printer for this method of flow control. The host must be capable of supporting this flow control method for it to function properly.

Cable Requirements

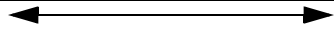
HOST	INTERCONNECTION	PRINTER
FG		1 FG (Frame Ground)
TD		3 RD (Receive Data)
		4 RTS (Request to Send)
		5 CTS (Clear to Send)
		6 DSR (Data Set Ready)
*		20 DTR (Data Terminal Ready)
SG		7 SG (Signal Ground)

* This connection at the host side of the interface would depend upon the pin that is being used as the Ready/Busy signal by the driving software. Typically on a PC, it would be either CTS (pin 5) or DSR (pin 6) on a DB-25 connector.

Data Streams

Once the flow control method has been chosen for the RS232C interface, the data stream must be sent in a specific manner. The **STX** and **ETX** Control characters must frame the data stream.

<STX><ESC>A..Job#1..<ESC>Z<ETX><STX><ESC>A..Job#n..**<ESC>Z<ETX>******

NOTE: All characters, including STX, ESC and ETX are in ASCII.

X-On/X-Off Flow Control

X-On/X-Off flow control must be used whenever hardware (Ready/Busy) flow control is not available or desirable. Instead of a voltage going high/low at pin 20, control characters representing “Printer Ready” (X-On = 11 hexadecimal) or “Printer Busy” (X-Off = 13 hexadecimal) are transmitted by the printer on pin 2 (Transmit Data) to the host. In order for this method of flow control to function correctly, the host must be capable of supporting it. **X-On/X-Off** operates in a manner similar to the function of pin 20 (**DTR**) as previously explained. When the printer is first switched on and goes on-line, an **X-On** is sent out. In the Single Job Buffer mode, when the printer receives a print job, it transmits an **X-Off** and begins printing. When it is done printing, it transmits an **X-On**. In the Multi Job Buffer mode, the printer sends an **X-Off** when the “Buffer Near Full” level is reached and a **X-On** when the data level of the buffer drops below the “Buffer Available” mark. When the printer is taken off-line manually, it transmits an **X-Off** indicating it cannot accept data. When it is placed back on line manually, it sends an **X-On**, indicating it is again available for receipt of data. If an error occurs during printing (paper out,), the printer sends nothing in the Single Job Buffer mode since the last character transmitted was an **X-Off**. When the error is cleared and the printer resumes printing, no **X-On** is sent until the current job is completed and the printer is once again read to receive the next job. If it is in the Multi Job Buffer mode, it sends an **X-Off** as soon as an error condition is detected. When the error is cleared and the printer is placed back on-line, it transmits an **X-On** indicating it is again ready to accept data.

Upon switch up, if no error conditions are present, the printer will continually send **X-On** characters at five millisecond intervals until it receives a transmission from the host.

Cable Requirements

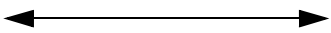
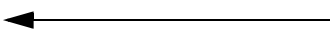
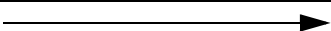
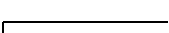
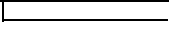
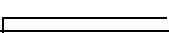
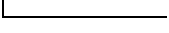
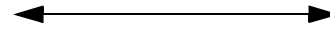
HOST	INTERCONNECTION	PRINTER
FG		1 FG (Frame Ground)
RD		2 TD (Transmit Data)
TD		3 RD (Receive Data)
		4 RTS (Request to Send)
		5 CTS (Clear to Send)
		6 DSR (Data Set Ready)
		20 DTR (Data Terminal Ready)
SG		7 SG (Signal Ground)

Data Streams

The Data streams for **X-On/X-Off** are constructed in the same way as they are for Ready/Busy flow control. The **STX** and **ETX** control characters must frame the data stream. (NOTE: All characters, including **STX**, **ESC** and **ETX** are in **ASCII**).







<STX><ESC>A..Job#1..<ESC>Z<ESC>A..Job#n..<ESC>Z<ETX

Example: <STX>A..Job#1..<ESC>Z<ETX>XXXX

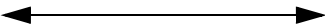
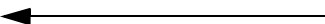
Bi-Directional Communications

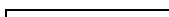
This is a two-way communications protocol between the host computer and the printer, thus enabling the host to check printer status. When this protocol is selected, there is no busy signal from the printer (pin 20, **DTR**, is always high). The host must request the complete status from the printer, including ready/busy. Whenever the host requests printer status, it transmits an **ENQ** to the printer and the printer will respond with its status within five milliseconds. If printing, it will respond upon finishing the current label, then resume printing. In order for this protocol to work properly, pin 6 (**DTR**) and pin 5 (**CTS**) must be held high by the host. One way to ensure these pins are always in the correct state is to tie pin 20 (**DTR**) to pin 6 (**DSR**) and pin 4 (**RTS**) to pin 5 (**CTS**) at the printer end of the cable.

Cable Requirements

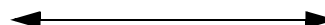
HOST	INTERCONNECTION	PRINTER
FG		1 FG (Frame Ground)
RD		2 TD (Transmit Data)
TD		3 RD (Receive Data)
		4 RTS (Request to Send)
		5 CTS (Clear to Send)
		6 DSR (Data Set Ready)
		20 DTR (Data Terminal Ready)
SG		7 SG (Signal Ground)

If a **CAN** (18 hexadecimal) is received by the printer, it will cancel the current print job and clear all data from the receive buffer.

Status Response

The Bi-Directional protocol is an advanced version of bi-directional communications where the printer can also report the number of labels remaining to be printed for the current print job. Upon receipt of an **ENQ** command, the printer responds with nine bytes of status information bounded by an **STX/ETX** pair. The Bi-Directional protocol works only in the Multi Job Buffer mode. The status information is defined as follows:

<STX>{2 Byte ID}{1 Status Byte}{6 Byte Label Remaining}<ETX>

ID - This is a two byte number identifying the current print job ID. The print job ID is defined using the **<ESC>ID** Job ID command transmitted with the print job, (see Job ID Store in the command listing for more information on how to use this command). The range is from 00 to 99.

Status - A single byte defining the current status of the printer, (see the Status Byte Definition table).

Label Remaining - Six bytes defining the number of labels remaining in the current print job. The range is from 000000 to 999999 labels.

If an **ENQ** is received after the print job specified in the ID bytes has been completed, or there is no data in the buffer, the printer will respond with two "space" characters (20 hexadecimal) for the ID number and six "zero" characters (30 hexadecimal) in the Remaining Labels bytes.

If a **CAN** (18 hexadecimal) command is received, it will stop the print job and clear all data from the receive and print buffers. A delay of five milliseconds or more is required before any new data can be downloaded. The **CAN** command is effective immediately upon receipt, even if the printer is off-line or in an error condition. The printer will return an **ACK** (06 hexadecimal) if there is no printer error condition and a **NAK** (15 hexadecimal) if an error condition exists.

Upon receipt of a valid print job (**<ESC>A...<ESC>Z**), and **ACK** (06 hexadecimal) will be returned by the printer if there are no errors and a **NAK** (16 hexadecimal) if a printer error exists.

Status Byte Definition, Bi-Directional Protocol

ASCII	HEX	DEFINITION
OFF-LINE		
0	30	No Errors
2	32	Buffer Near Full
ON-LINE, WAITING FOR DATA		
A	41	No Errors
C	43	Buffer Near Full
ON-LINE, PRINTING		
G	47	No Errors
I	49	Buffer Near Full
ON-LINE, WAITING TO DISPENSE A LABEL		
M	4D	No Errors
O	4F	Buffer Near Full
ON-LINE COMPILING PRINT JOB		
S	53	No Errors
U	55	Buffer Near Full
OFF-LINE, ERROR CONDITION		
a	61	Receive Buffer Full
b	62	Head Open
c	63	Paper End
e	65	Media Error
f	66	Sensor Error
g	67	Head Error
i	68	Memory Card Error
j	6A	Cutter Error
k	6B	Other Error Condition

4.5 Centronics Parallel Interface

Electrical Specifications

Printer Connector	AMP 57-40360 (DDK) or equivalent
Cable Connector	AMP 57-30360 (DDK) or equivalent
Cable Length	3m or less
Signal Level	High = +2.4V to +5.0V Low = 0V to -0.4V

Data Streams

Multi Job Buffer:<STX><ESC>A..Job#1..<ESC>Z<ETX>
<STX><ESC>A..Job#n..<ESC>Z<ETX>

Note that for parallel communications, the STX and ETX characters are not required.

Centronics Parallel Interface Pin Assignments

PIN	SIGNAL	DIRECTION	PIN	SIGNAL	DIRECTION
1	STROBE	To Printer	19	STROBE Return	Reference
2	DATA 1	To Printer	20	DATA 1 Return	Reference
3	DATA 2	To Printer	21	DATA 2 Return	Reference
4	DATA 3	To Printer	22	DATA 3 Return	Reference
5	DATA 4	To Printer	23	DATA 4 Return	Reference
6	DATA 5	To Printer	24	DATA 5 Return	Reference
7	DATA 6	To Printer	25	DATA 6 Return	Reference
8	DATA 7	To Printer	26	DATA 7 Return	Reference
9	DATA 8	To Printer	27	DATA 8 Return	Reference
10	ACK	To Printer	28	ACK Return	Reference
11	BUSY	To Host	29	BUSY Return	Reference
12	PTR ERROR	To Host	30	PE Return	Reference
13	SELECT	To Host	31		
14			32	FAULT	To Host
15			33		
16			34		
17	FG	Frame Ground	35		
18	+5V (Z=24K ohm)		36		

4.6 Accessory (EXT) Connector

The Accessory (or EXT) connector on the printer is intended for use with the external printer accessories such as label rewinders or applicators. The 14 pin Centronics type connector provides a choice of four different output signals along with various error conditions.

PIN Assignments

PIN	DIRECTION	SIGNAL DESCRIPTION
1	To Host	Label Out - This pin goes low (0V) when a "label out" error exists.
2	Reference	Signal Ground
4	To Host	Error - This pin goes low when the printer detects an error condition such as head open or receiving buffer full.
5	To Printer	Print Start - The printer will print one label when this pin is pulled to ground. This signal must be enabled by placing switch DSW3-5 on the Control Panel in the ON position.
6	To Host	End Print - It is used to drive an applicator or other external device requiring synchronization with the print cycle. You may choose between four types of output signals using control panel DSW3-6 and DSW3-7 selections.
7	To Printer	Print Repeat - The printer repeatedly prints the current label in the print buffer immediately after receiving this signal. DSW3-8 must be ON.
10	To Host	+12V - Used to power accessory items.
12	To Host	+24V - Used to power accessory items.
13	To Host	Vcc - +5V
14	Reference	Frame Ground

NOTE: The signals on pins 1, 3 4 and 6 each have an open collector output. These pins normally measure +.07V maximum when a true condition exists. If a false condition occurs, the voltage will drop to 0V. To achieve a signal level of +5V, you must add a 1K ohm,

¼ W pull-up resistor between the open collector output pin and Vcc (pin 13) as illustrated. This will provide a signal level of +5V for a true condition and 0V when a false condition exists. The maximum voltage that can be applied to these pins is +50V and the maximum current they can sink is 500 milliamps.

External Output Signal Types

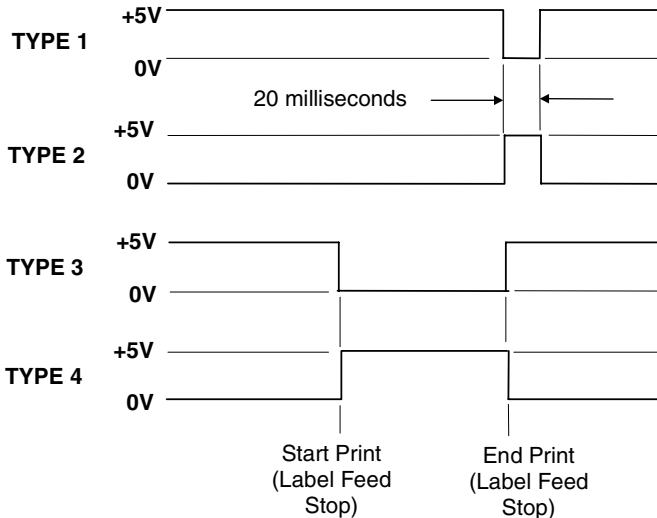
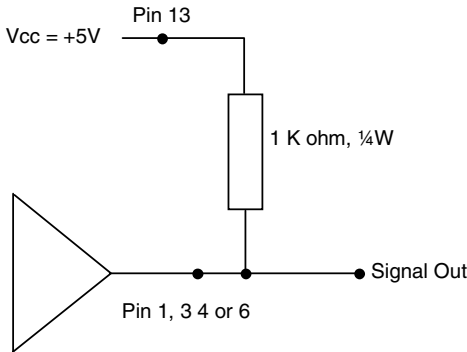

5. Loading Labels

1. Open the print head assembly by pulling the head latch toward the front of the printer. The print head assembly is spring-loaded and will automatically open as soon as the head latch is disengaged.
2. Push the label unwind guides to the outside of the printer to give the maximum label width.

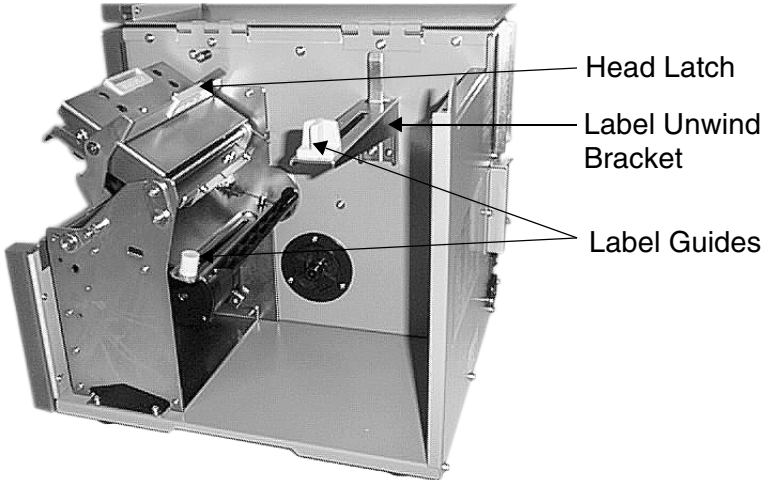

3. Load the media roll onto the label unwind bracket so that the printing side of the labels faces upwards as it unwinds from the roll. Push the roll all the way to the inside of the printer and the label unwind guide snugly against the outside of the label roll.

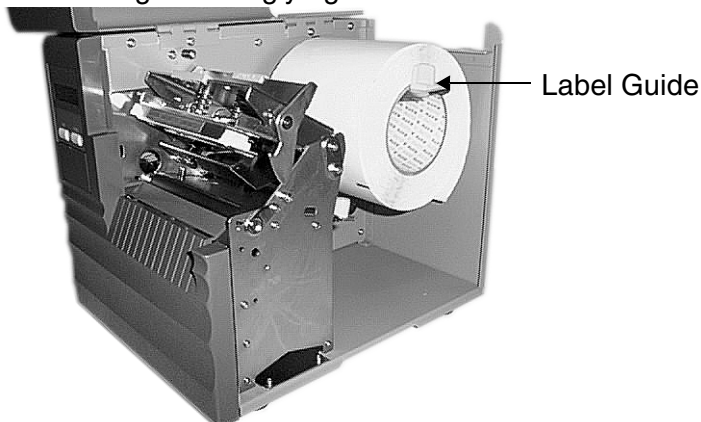

4. Feed the labels under the label guide shaft, through the print head assembly and out of the front of the printer.

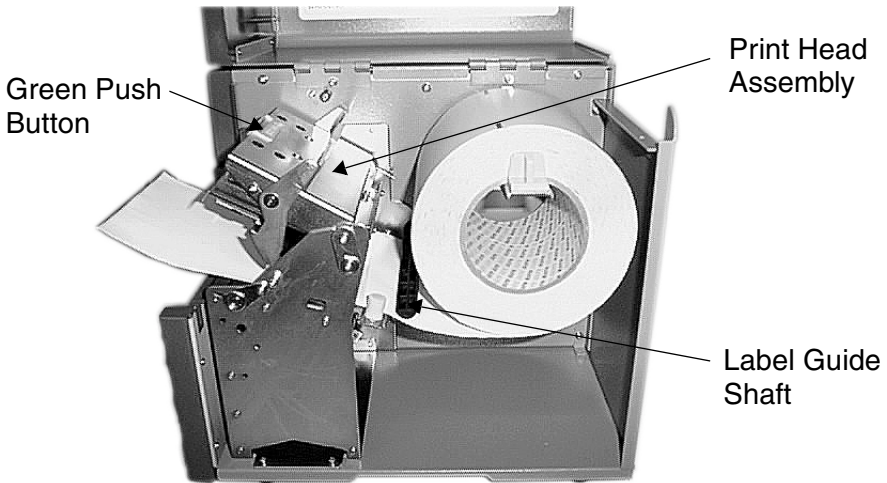

Note: When the label dispenser option has been installed, remove 600 to 800 mm of labels from the backing and feed the backing back through the label dispense path.

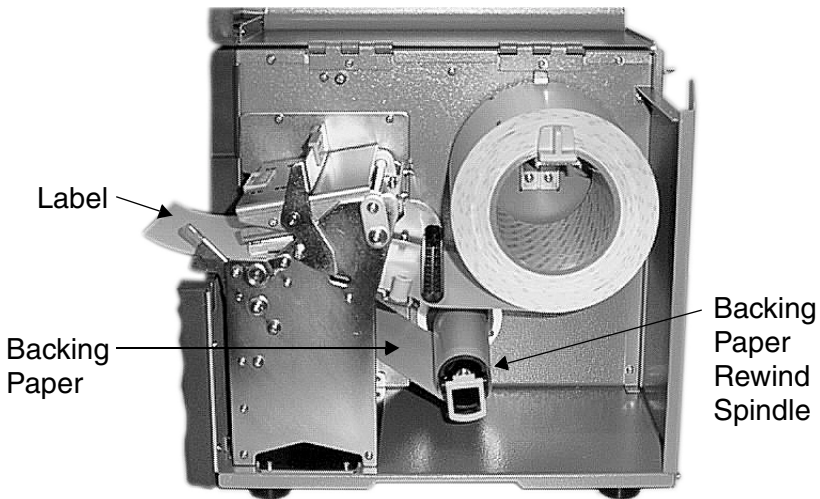

5. Inspect the label route and check that the path matches that illustrated in the label loading diagram. Set the adjustable label guides to keep the labels against the backplate of the printer. Close the print head assembly by pushing down the the green button.

This page is intentionally left blank.

6. Troubleshooting

6.1 Overview

The design of the SATO M-5900RV printer is based upon proven technology and reliable components. When a problem occurs, the solution can be easily traced using the troubleshooting tables in this section. This table list symptoms, probable causes, and suggested corrective actions.

Both print quality and general operational problems are listed in the troubleshooting table.

Make sure the basics have been checked before deciding you are unable to proceed any further. To help you this section has been divided into the following parts:

- Initial Checklist
- Centronics Parallel Interface
- RS232C Serial Interface
- Error Signals
- Print Quality Problems

6.2 Initial Checklist

If you are unable to produce output on the M-5900RV, check the following before deciding you are unable to proceed any further.

1. Is the printer powered on and **ON-LINE**?
2. Is the Print Head and the Label Hold Down in the down and latched position?

Other areas that may need looking at include:

6.3 Troubleshooting the Centronics (Parallel) Interface

1. Is the IBM parallel printer cable connected securely to your parallel port (DB-25S Female) on the PC and to the Centronics connector on the printer?

Warning: **Never connect or disconnect interface cables (or use a switch box) with power applied to either the printer or the host. This may cause damage to the interface circuitry and is not covered by warranty.**

2. Is there more than one parallel interface port on your PC (LPT1, LPT2, etc.)? If so, make sure you are sending data out the correct port.
3. When you send the print job to the printer, and it does not respond, do you get an error message on your PC that says "Device Fault" or something similar?

This may mean that the computer doesn't know the printer is there. Verify that:

- a. Both ends of the cable are securely inserted into their respective connectors.
 - b. The printer is **ON-LINE**.
 - c. The cable is not defective. There are other things that can cause this error message on your computer, but at this stage, a defective cable may be one of the reasons.
4. When you send the print job to the printer and it does not respond, and there is no error message on the PC:
 - a. Check your data stream for some of the basics. Is your job framed as follows?

<ESC>A—DATA---<ESC>Z

- b. Verify that you've included all required parameters in the data stream.
- c. Verify the following:
 - You have not typed a "0" (zero) for an "O" (letter) or vice-versa.
 - You have not missed any <ESC> characters where they're needed.
 - Make sure all printer command codes are capital letters.
 - Your protocol codes are set for Standard or Non-Standard and your data stream is consistent with these.
5. If you've checked all of the above and the printer still isn't printing, you may want to try a Receive Buffer Hex Dump to determine what (if anything) the printer is receiving from your computer. See Hex Dump Diagnostic Labels.

The Centronics port is now listening for incoming data. Send your print job. The printer will now print (only once) a Hexadecimal (Hex) Dump of everything it received from the host computer. Each 2-digit hexadecimal character represents a character the printer received. It may be tedious, but now you can analyze and troubleshoot the data stream.
6. While checking the Hex Dump printout, if you notice 0D 0A (Carriage Return and Line Feed) characters throughout. The command string should be continuous. CR or LF characters are not allowed between the Start Command (<ESC>A) and the Stop Command (<ESC>Z). If you are using BASIC, it may be adding these characters automatically as the line wraps. Adding a "width" statement to your program can help to suppress these extra 0D 0A characters by expanding the line length up to 255 characters.

If you're not programming in BASIC, check to see if you have an equivalent statement in the language you're using to suppress extra carriage returns and line feeds from your data being sent out to the printer. We want the data stream to be one complete line going to the printer.

6.4 Troubleshooting the RS232C (Serial) Interface

1. Is the RS232C Serial cable connected securely to your serial port on the PC (DB-25S Male) and to the RS232C connector on the printer?

Warning: Never connect or disconnect interface cables (or use a switch box) with power applied to either the printer or the host. This may cause damage to the interface circuitry and is not covered by warranty.

2. Is the cable defective? At the very least, you should be using a "Null Modem Cable," which crosses pins in a specific manner. This should enable your printer to print. We recommend that you use a cable built to specifications described in Section 4, Interface Specifications.
3. Check for obvious errors in the data stream. Remember that all print jobs for serial data must be framed by an STX and ETX.
4. If after sending your job to the printer, it only "beeps" (or displays a **FRAMING ERROR** message on the LCD panel), you may have a configuration problem. There may be some inconsistencies with the Baud Rate, Parity, Data Bits, or Stop Bits in relation to your host computer. If you are confused as to what the printer's current RS232 settings are, you may choose the SATO defaults (all DIP switches in the OFF position) to achieve 9600 baud, no parity, 8 databits, and 1 stop bit.
5. If you still are unable to get printer output, try the Hex Dump as described in Step 5 under the Centronics Interface troubleshooting. In this case, the printer monitors its RS232C interface for incoming data.

6.5 Error Signals

LCD MESSAGE	AUDIBLE BEEP	ERROR CONDITION	TO CLEAR
Machine Error	1 Long	Machine Error	Switch power ON/OFF
EEPROM Error	1 Long	EEPROM Read/Write	Switch power ON/OFF
Head Error	1 Long	Head	Switch power ON/OFF
Sensor Error	3 Short	Sensor	Switch power ON/OFF
Card R/W Error	1 Long	Memory Card Read/Write	Switch power ON/OFF
Card Low Battery	1 Long	Memory Card Battery Low	Switch power ON/OFF
Head Open	3 Short	Head Open	Close Head Lever
Cover Open	3 Short	Front/Top Door Open	Close Doors
Parity Error	3 Short	RS232 Parity Error	Switch power ON/OFF
Overrun Error	3 Short	RS232 Overrun Error	Switch power ON/OFF
Framing Error	3 Short	RS232 Framing Error	Switch power ON/OFF
Buffer Over	3 Short	Buffer Overflow	Switch power ON/OFF
Paper End	3 Short	Label End	Open/Close Head
Cutter Error	3 Short	Cutter Malfunction	Open/Close Head

6.6 Print Quality Problems

☺ The suggested actions may be carried out by the end-user.

✘ The suggested actions should only be carried out by experienced service staff. Recall your reseller or service agent.

Symptom	Probable Cause	Suggested Corrective Action
Image Voids	Poor quality labels	Use thermal direct compatible stock ☺
	Damaged electronics	Replace circuit board ✘
	Damaged Platen	Replace Platen ✘
Light Images	Poor quality labels	Use thermal direct compatible stock ☺
	Low print head energy/darkness	Adjust darkness control ☺
	Low print head pressure	Use correct head pressure position ✘
	Foreign material on head	Clean head and platen ☺
	Poor head alignment	Align Print Head ✘
	Excessive print speed	Reduce print speed setting ☺
Smearing	Poor quality labels	Select better suited labels ☺
	Foreign material on head/platen	Clean head and platen ☺
	Foreign material on labels	Use high quality label stock ☺
	Excessive print head energy	Adjust darkness control ☺
	Excessive print speed	Adjust print speed ☺
	Excessive head pressure	Use correct head pressure position ✘
No Label Movement	Loose/broken platen drive belt	Adjust/replace belt ✘
	Incorrect label pitch sensor selected	Select correct label sensor type (DSW2-2) ☺
	No +24 volt output	Replace fuse on main PCB Test power supply and replace if required ✘
	Loose set screw on platen pulley/stepper motor	Tighten set screws ✘

No Printed Image	Print head not connected	Verify print head connector fully seated at head and main PCB ☺
	Label upside down	Turn around ☺
	No + 24 volt output	Test power supply and replace if required ✖
No Printed Image	Damaged print head	Replace print head ✖
	Damaged electronics	Replace circuit board ✖

This page is intentionally left blank.

7. Cleaning and Maintenance

Proper handling

The print head contains a precise printing surface that must be carefully protected from mechanical damage. Extreme care must be exercised during handling and installation to prevent scratching, chipping, denting or otherwise damaging the exposed surface.

Cleaning

Only solvent, i.e. alcohol and other cleaning methods recommended by SATO should be used to periodically remove paper residue from the print head. Apply carefully with a cotton swab. Frequency of cleaning depends upon paper type and mechanical factors and should be completed at each label roll change. Only clean when the printer is switched off and cooled to room temperature to avoid thermal shock damage.

Do not operate the machine for at least 15 minutes after cleaning to ensure the head is totally dry of any cleaning fluids.

Do not use abrasive materials in cleaning. However, SEG supplies a special lapping film, **SEG-No. 1938**, to clean the print head surface.

7.1 Cleaning the Print Head and Platen

7.1.1 Cleaning the Print Head using Print Head Cleaner

1. Switch off the power to the printer and open the cover.
2. Open the print head assembly by pulling the head latch toward the front of the printer. The print head assembly is spring-loaded and will automatically open as soon as the head latch is disengaged.
3. Apply any SATO approved thermal print head cleaner to a cotton swab.
4. The print head faces downward along the front edge of the assembly. Pass the end of the dampened swab along the entire width of the print head.
5. Check for any black colouring or adhesive on the swab after cleaning. Repeat as necessary until the swab stays clean, after being passed over the head.
6. The head should be cleaned at least every time the label roll is changed and more often in dusty environments.

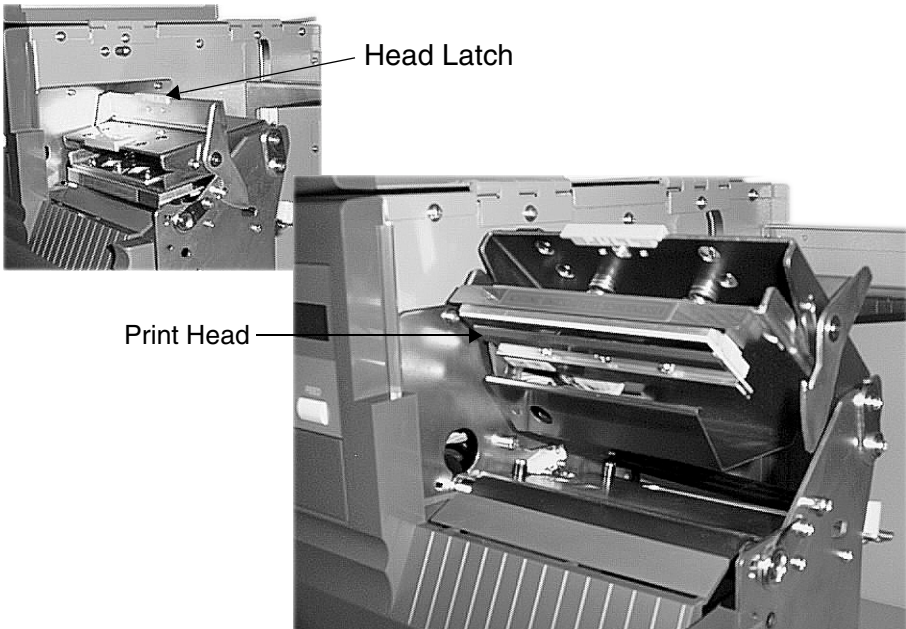

7.1.2 Cleaning the Print Head using the Lapping Film

1. Switch off the power to the printer.
2. Place the lapping film between print head and platen with the abrasive side face-up. Close the print head with the head latch.
3. Pull the cleaning film by hand slowly toward the front of the printer.
4. Repeat steps 3 and 4 two or three times.
5. Finally, clean the print head with a print head cleaner as described previously.

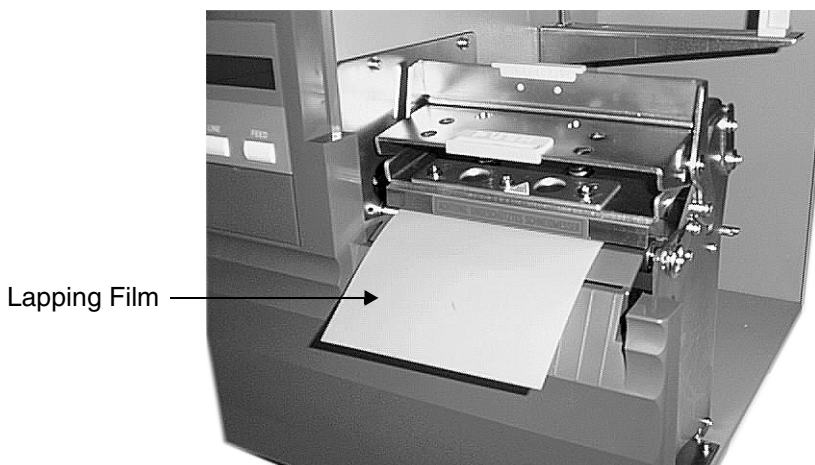

7.2 Cleaning the Platen and Label Guides

1. Switch off the power to the printer and open the cover .
2. Open the print head assembly by pulling the head latch toward the front of the printer. The print head assembly is spring-loaded and will automatically open as soon as the head latch is disengaged.
3. Apply any SATO approved cleaner to a clean wipe.
4. The platen is the rubber roller directly below the print head. It should be cleaned of any label residue.
5. The label unwind guides and the label guide shaft used in guiding the labels through the printer must be cleaned of any label residue or other foreign material.
6. Repeat as necessary. The platen and label guides should be cleaned whenever foreign matter such as dust or adhesive is present.

Platen

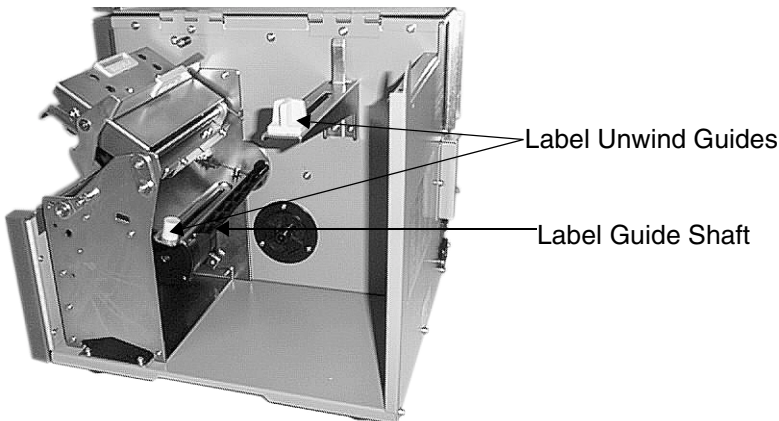
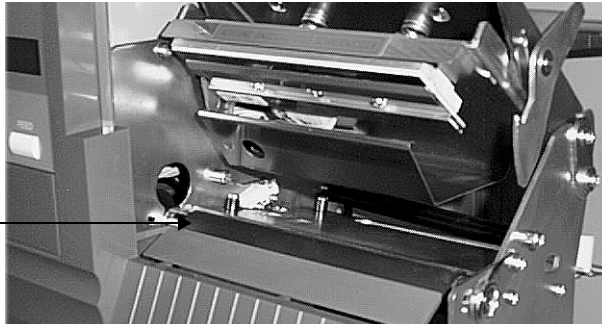

Label Unwind Guides

Label Guide Shaft

7.3 Cleaning the Sensors

There are two sensors that are used to control the positioning of the label. One is a transmissive see-through sensor that detects the edge of the label by looking through the backing paper which is translucent and detecting the presence of the opaque label. The other is a reflective sensor that detects the light reflected from the bottom of the label liner. When dust, dirt or other foreign matter interferes with the light path of either of these sensors, the result is erratic label positioning. These sensors should be cleaned regularly, at least every two rolls of label.

1. Switch off the power to the printer and open the cover .
2. Open the print head assembly by pulling the head latch toward the front of the printer. The print head assembly is spring-loaded and will automatically open as soon as the head latch is disengaged.
3. Apply any SATO approved cleaner to a clean wipe.
4. The sensors must be cleaned of any label residue or other foreign material.
5. Repeat as necessary. The sensors should be cleaned whenever foreign matter such as dust or adhesive is present

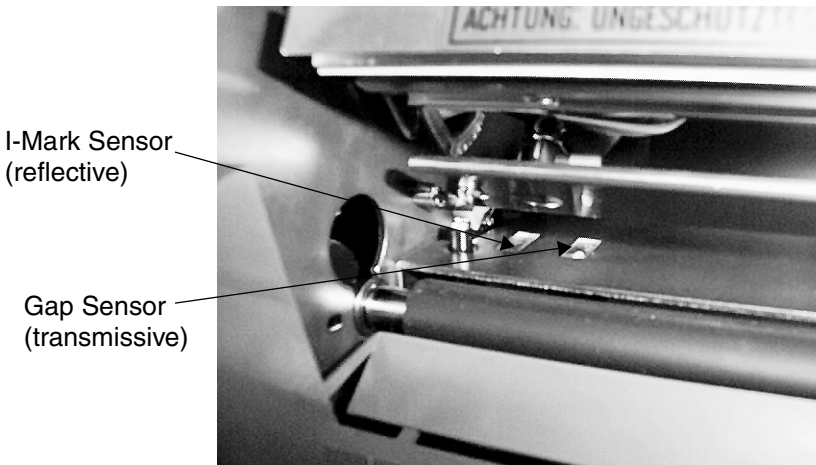

This page is intentionally left blank.

This page is intentionally left blank.